

Features

- 28.7" x 15.08" x 28.03"
- 1.28 GPF
- 1000 Grams MAP
- Fully Glazed Trap
- 12" Rough In
- 3" R&T A2102 Flush Valve
- R&T A126 Fill Valve

CODES:

ASME A112.19.3/CSA B45.4, cUPC



Product Diagram

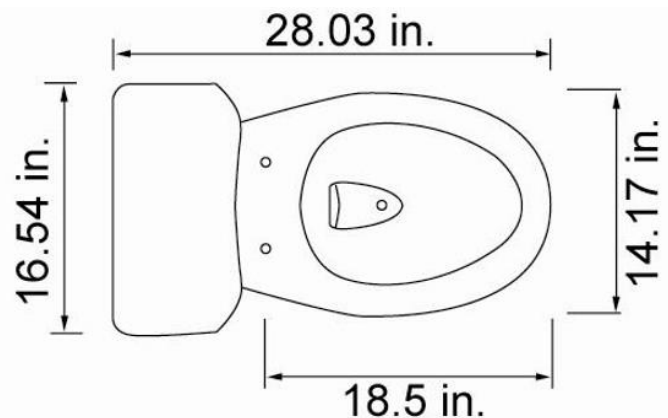
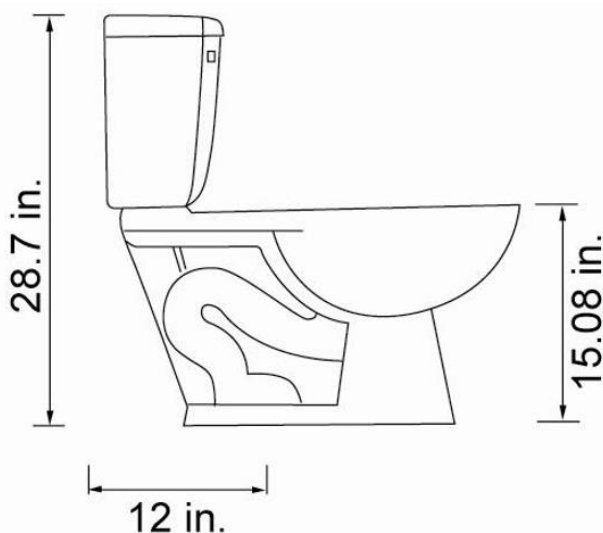

1-877-500-SINK (7465)

WEST COAST WAREHOUSE: 510-667-9998  EAST COAST WAREHOUSE: 404-691-5088

WWW.AMERISINK.COM